

## Special Reviews

---

### DIFFERENTIAL THERMAL ANALYSIS STUDIES OF CHEMICAL SYSTEMS IN SEALED CELLS

A. V. SANTORO, E. J. BARRETT and H. W. HOYER

*Hunter College of the City University of New York, New York, U.S.A.*

(Received March 26, 1970)

Many chemical systems illustrating major reaction types may be conveniently studied by differential thermal analysis. The problems of vaporization and sublimation have been avoided through the use of sealed glass vials. Sample sizes are in the range of 10 to 100 milligrams. This size though small is still more than adequate for chemical analysis by instrumental methods such as infrared spectroscopy and gas chromatography.

We have carried out extensive research [1-7] utilizing the technique of sealed cells. Because the details of our technique have evolved during the course of several publications, correspondence and inquiries to the authors have suggested the need for a detailed review of this procedure. Studies involving chemical reactions cannot be carried out by conventional DTA without great difficulty. This is true for a number of reasons. Vaporization and sublimation may occur before appreciable reaction takes place or reaction may occur above the boiling point of the sample. Such processes produce extraneous thermal effects which tend to mask or distort those produced by the chemical reaction. The obvious solution to the problems mentioned above would be to carry out the reaction in a sealed system. We have found that small glass vials when properly sealed can withstand pressures up to 45 atmospheres.

#### **Description of technique**

The apparatus that we have used utilizes the duPont Model 900 Differential Thermal Analyzer in conjunction with the calorimeter cell (see Fig. 1 for a schematic diagram of the calorimeter cell), but any apparatus of similar design can be used. The calorimeter cell has the particular advantage of the vial being in a constant temperature environment thus eliminating a temperature gradient effect. The reaction vials, available from the duPont Co., are four millimeters in diameter and 2.8 centimeters in length. Again, any similar flat bottom thin walled vial can be used. Small known quantities of materials are sealed in the vials, and the DTA experiment is carried out in the calorimeter cell. It is often desirable to exclude oxygen from the reaction vial. In such cases the reactant may be distilled

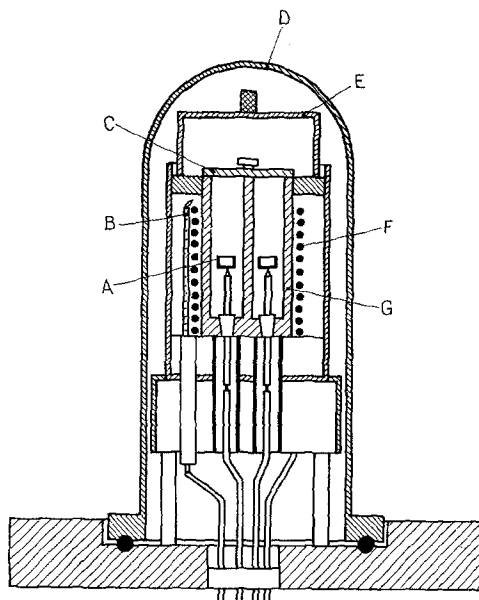

Fig. 1. DuPont calorimeter cell, A: sample holder; B: control thermocouple; C: heating block cover; D: bell jar; E: insulating lid, F: heater; G: heating block

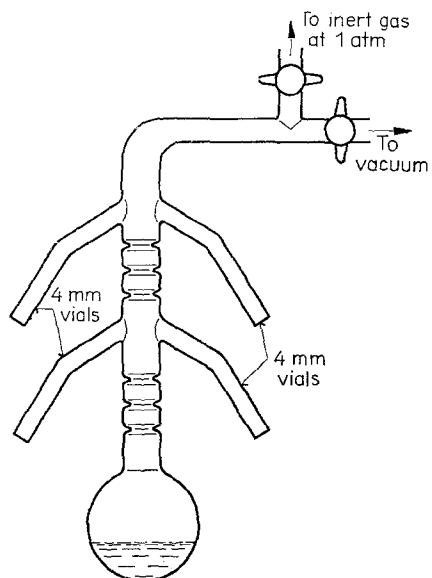

Fig. 2. Glass distillation apparatus

directly into the vials either under vacuum or in an inert gas atmosphere, utilizing an all-glass distillation tree similar to that shown in Fig. 2. The vial is simultaneously sealed and removed from the tree and an empty vial may then be sealed to the distillation apparatus to replace the original. It is essential that during the sealing process the sample temperature be kept low enough to prevent chemical reaction or decomposition. We therefore surround the vial with a small quantity of dry ice when sealing it.

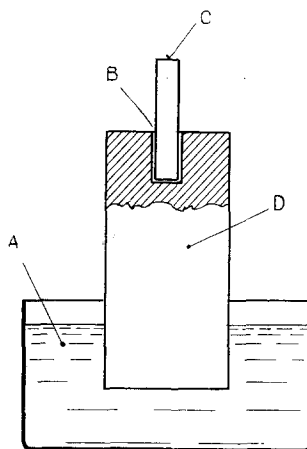

Fig. 3. Jig for sealing glass cells. A: dry ice — acetone bath; B: vial sealed at that point; C: sample vial; D: aluminium block

Under normal circumstances, when it is not necessary to distill the sample directly into the vial, the vial is sealed using the jig shown in Fig. 3. A drop of water is placed in the well and the vial inserted into the opening. The temperature of the jig and sample is reduced by immersing the lower part of the jig in a dry ice-acetone bath. The jig is removed from the bath and the vial immediately sealed with a micro torch. Care is taken to avoid the formation of microscopic pinholes during the sealing process by examining each vial under a magnifying glass before running the thermogram.

### Examples

This technique has been applied to a variety of different chemical reactions as shown in Figs 4–8. For example, the effect of a catalyst on the rate of reaction is demonstrated for the *cis-trans* isomerization of stilben [1] and oleic acid [4] (Figs 4, 5), the polymerization of styrene [3] (Fig. 6) and the Diels-Alder

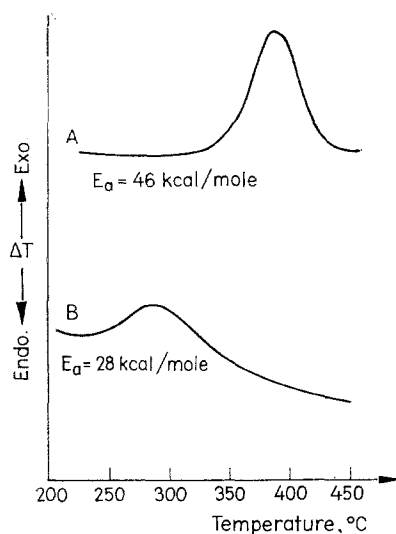

Fig. 4. *Cis* to *trans* isomerization of stilbene. A: uncatalyzed stilbene; B: Pd catalyzed stilbene

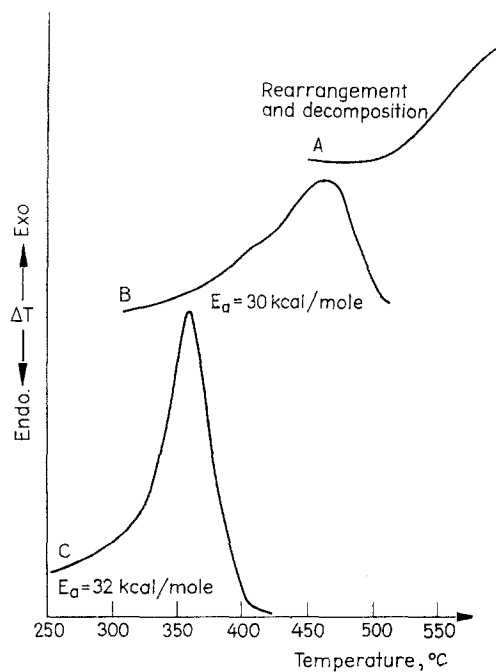

Fig. 5. *Cis* to *trans* isomerization of oleic acid to elaidic acid. A: uncatalyzed oleic acid; B: Se catalyzed oleic acid; C: iodine catalyzed oleic acid

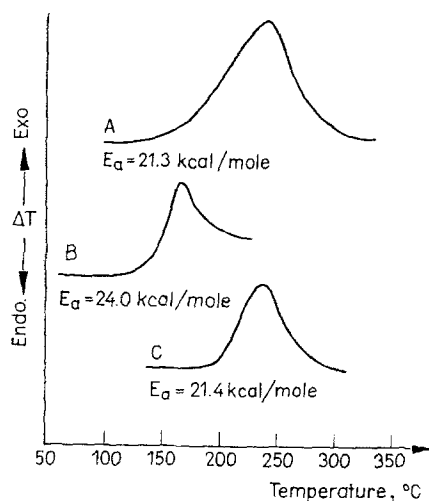

Fig. 6. Polymerization of styrene. A: uncatalyzed styrene; B: benzoyl peroxide catalyzed styrene; C: styrene in toluene solution

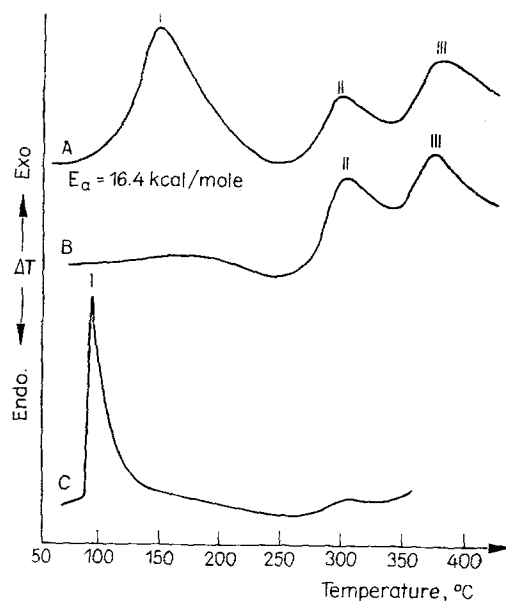

Fig. 7. The Diels-Alder reaction. A: uncatalyzed cyclopentadiene; B: dicyclopentadiene; C: HCl catalyzed cyclopentadiene. Reactions: I: dimerization of cyclopentadiene; II: formation of polymer and conversion of endo-dicyclopentadiene to exo-dicyclopentadiene; III: decomposition and further polymerization

dimerization of cyclopentadiene [2] (Fig. 7). Kinetic data is readily attainable either by the method of Borhardt and Daniels [8] or that of Piloyan et al. [9]. High energy compounds which are normally difficult and hazardous to study can be readily handled by this technique as is shown in Fig. 8 for dimethylhydrazine [5].

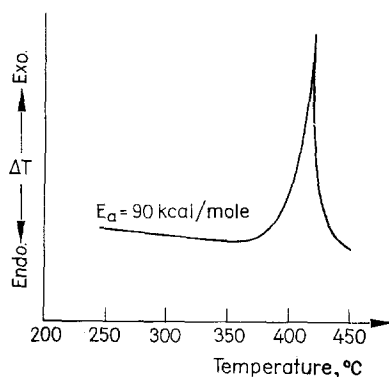

Fig. 8. Decomposition of dimethyl hydrazine

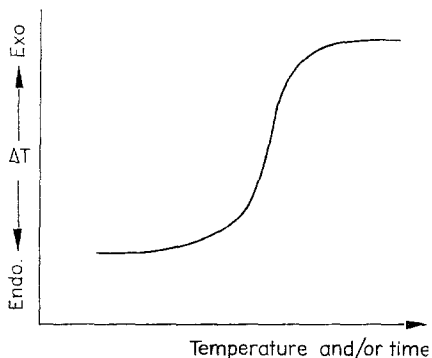

Fig. 9. Sigmoid type DTA curve

At times one observes a sigmoidal type isotherm similar to that shown in Fig. 9. While this caused us considerable initial concern, we have demonstrated that such isotherms are caused by a change in heat capacity associated with a transition from a system consisting of liquid in equilibrium with vapor to one consisting entirely of vapor. We have subsequently used this phenomenon to measure the critical temperature of liquids [6].

From time to time minor explosions do occur, resulting in no more damage other than slightly distorting the thermocouple cups. This eventually necessitates replacement of the thermocouples. This problem can be virtually eliminated by estimating the weight of the sample which would just generate a pressure of 45 atmospheres at the maximum temperature of the DTA experiment assuming ideal gas behavior for all gaseous reaction products.

Although a number of different heating rates have been tried, a rate of 20° per minute provides us with DTA curves of sufficient resolution for kinetic analysis within a reasonable period of time. Vials under pressure after a run should be disposed of utilizing suitable precautions. Goggles should be worn and the vial crushed in a large container of water.

### Conclusions

While only a small number of systems have as yet been studied by this technique, it will be apparent to the reader that the potential applications of the method are limited only by the number of thermally induced reactions of moderate  $\Delta H$  which occur at temperatures up to 500° and pressures up to 45 atmospheres.

It is apparent that the use of sealed reaction vials in the calorimeter cell of the model 900 Differential Thermal Analyzer makes it possible to study a wide variety of thermally induced reactions. The technique is sensitive and rapid and yields kinetic data with an accuracy equivalent to that of more conventional methods.

### References

1. A. V. SANTORO, E. J. BARRETT and H. W. HOYER, *J. Am. Chem. Soc.*, 89 (1967) 4545.
2. E. J. BARRETT, H. W. HOYER and A. V. SANTORO, *Tetrahedron Letters*, 5 (1968) 603.
3. H. W. HOYER, A. V. SANTORO and E. J. BARRETT, *J. Polymer. Sci., Part A-1*, 6 (1968) 1033.
4. A. V. SANTORO, E. J. BARRETT and H. W. HOYER, *Tetrahedron Letters*, 19 (1968) 2297.
5. E. J. BARRETT, H. W. HOYER and A. V. SANTORO, *Anal. Lett.*, 285 (1968).
6. H. W. HOYER, A. V. SANTORO and E. J. BARRETT, *J. Phys. Chem.*, 72 (1968) 4312.
7. H. W. HOYER, *J. Am. Chem. Soc.*, 90 (1968) 2480.
8. H. J. BORCHARDT and F. DANIELS, *J. Am. Chem. Soc.*, 79 (1957) 41.
9. G. O. PILOYAN, I. D. RYABCHIKOV and O. S. NOVIKA, *Nature*, 212 (1966) 1229.

RÉSUMÉ — De nombreux systèmes chimiques illustrant les principaux types de réaction peuvent être étudiés d'une manière commode par analyse thermique différentielle. On élimine les problèmes provenant de la vaporisation et de la sublimation par l'emploi d'ampoules de verre scellées. On prend des échantillons de 10 à 100 mg. Cette quantité, quoique déjà faible, est plus que suffisante pour faire l'analyse chimique par des méthodes instrumentales comme la spectroscopie infrarouge et la chromatographie en phase gazeuse.

ZUSAMMENFASSUNG — Die Differentialthermoanalyse ist zur Untersuchung vieler Systeme mit den wesentlichsten Reaktionstypen geeignet. Durch Verdampfen und Sublimieren verursachte Veränderungen beseitigt man durch die Verwendung verschlossener Glasampullen. Die Größe der Probe bewegt sich von 10 bis 100 mg. Diese Menge reicht aus, um eine chemische Analyse durch Infrarotspektroskopie oder Gaschromatographie durchzuführen.

Резюме — Много химических систем, иллюстрированных реакциями разного типа, можно изучать методом ДТА. Во избежание испарения и сублимации веществ используются закрытые стеклянные ампулы. Навески образцов составляют 10—100 мг. Такие навески хотя и являются маленькими, но они больше навесок, необходимых для инструментальных методов химического анализа, таких как инфракрасная спектроскопия и газовая хроматография.